



Large Dry Chemical Skid Units

Chemguard designs and manufactures our own line of large, expertly engineered Dry Chemical Systems. The units are an effective means of controlling 3-dimensional Class "B" (flammable liquid) and Class "C" (electrical) fires. Chemguard's Dry Chemical Systems will effectively extinguish large flowing fuel and gas/liquid pressure fires where other types of equipment and agents may be ineffective. Our systems are frequently used in offshore locations. These units can be provided in several different sizes ranging from 200 lbs up to 2,500 lbs. The dry chemical is contained within an ASME coded pressure vessel with a working pressure of 200 psi. The dry chemical is expelled by nitrogen cylinders mounted on the skid unit. The nitrogen is supplied through a pressure-regulating valve into a manifold and then piped to the dry chemical storage container. The standard dry chemical skid is supplied with either one or two hose reels. Each hose is equipped with 100' of 1" hard rubber hose and a nozzle with ball-shutoff valve.

FEATURES

- Rugged construction – skid constructed of structural steel
- One-man operation
- Manually operated – allows the operator to use only the quantity of dry chemical necessary to suppress a fire
- Completely self-contained (no outside power source is required)
- ASME coded pressure vessel
- 200-psi working pressure
- 250-psi design pressure
- Hose reels with brakes and easily operated hand crank

- Five standard sized skids are available. Other sizes can be manufactured on request.
- Skids can be adapted for either floor or trailer mounting.
- Flow rate of 5 to 8 lbs. per sec.

OPTIONS

- Remote hose reel
- Turret nozzle
- Corrosion resistant package
- Units piped into a fixed system

CONTAINER CAPACITIES

Chemguard Unit Dry Chemical Capacities

PART NO:	ABC	BC	PK
CDC200	200 lbs.	230 lbs.	200 lbs.
CDC500	500 lbs.	600 lbs.	500 lbs.
CDC1000	1050 lbs.	1200 lbs.	1050 lbs.
CDC1500	1400 lbs.	1550 lbs.	1400 lbs.
CDC2000	2000 lbs.	2250 lbs.	2000 lbs.
CDC2500	2300 lbs.	2600 lbs.	2300 lbs.

PK - Potassium Bicarbonate Dry Chemical
BC - Sodium Bicarbonate Dry Chemical
ABC - Monoammonium Phosphate

CHEMGuard

204 S. 6th Ave • Mansfield, Tx 76063 • (817) 473-9964 • FAX (817) 473-0606

www.chemguard.com

ORDERING INFORMATION

Part No.	Length	Width	Height	Weight	N ² CYC	Reels
CDC200	56"	39"	35"	730 lbs.	1	1
CDC500	72"	48"	41"	1700 lbs.	1	1
CDC1000	110"	64"	64"	3400 lbs.	2	2
CDC1500	110"	64"	64"	3800 lbs.	3	2
CDC2500	110"	69"	69"	4800 lbs.	5	2

Note:

1. Larger units available upon request.
2. Fixed system units available upon request.

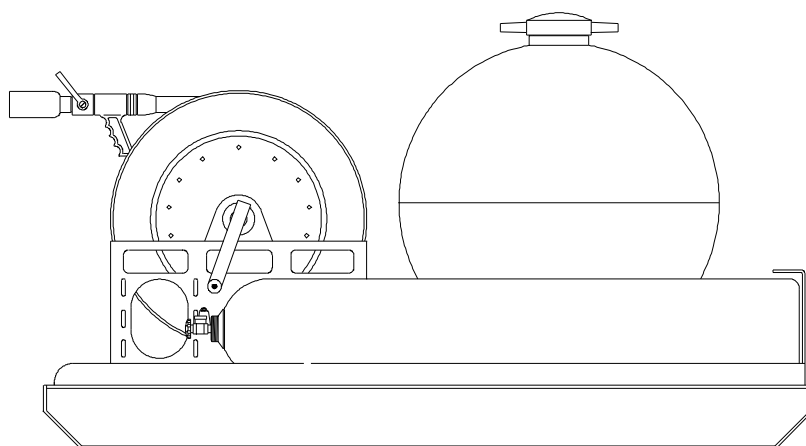
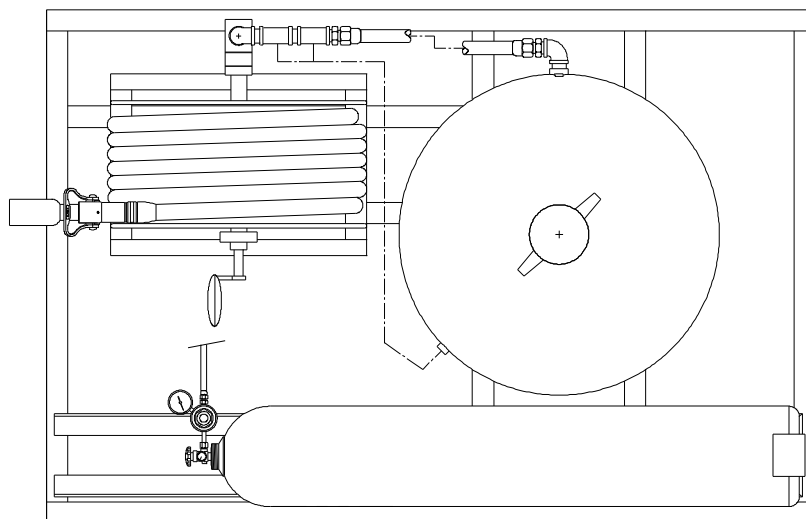

CDC500 shown

CHEMGUARD
204 S. 6th Ave • Mansfield, Tx 76063 • (817) 473-9964 • FAX (817) 473-0606
www.chemguard.com